

KENWOOD

KDC-C800

COMPACT DISC AUTO CHANGER INSTRUCTION MANUAL

CHANGEUR AUTOMATIQUE DE DISQUES COMPACTS MODE D'EMPLOI

CD-WECHSLER BEDIENUNGSANLEITUNG

CD-WESSELAAR GEBRUIKSAANWIJZING

LETTORE MULTI-CD AUTOMATICO ISTRUZIONI PER L'USO

CAMBIADOR AUTOMATICO DE DISCOS COMPACTOS MANUAL DE INSTRUCCIONES

KENWOOD CORPORATION



Take the time to read through this instruction manual. Familiarity with installation and operation procedures will help you obtain the best performance from your new compact disc auto changer.

For your records

Record the serial number, found on the back of the unit, in the spaces designated on the warranty card, and in the space provided below. Refer to the model and serial numbers whenever you call upon your KENWOOD dealer for information or service on the product.

Model KDC-C800 Serial number _____

WARNING

CAUTION

The use of optical instruments with this product will increase eye hazard.

INFORMATION

This equipment generates and uses radio frequency energy and if not installed and used properly, that is, in strict accordance with the manufacturer's instructions, may cause interference to radio and television reception. It has been type tested and found to comply with the limits for a Class B computing device in accordance with the specifications in Subpart J of Part 15 of FCC Rules, which are designed to provide reasonable protection against such interference in a residential installation. However, there is no guarantee that interference will not occur in a particular installation. If this equipment does cause interference to radio or television reception, which can be determined by turning the equipment off and on, the user is encouraged to try to correct the interference by one or more of the following measures:

Reorient the receiving antenna

Relocate this equipment with respect to the receiver

Move this equipment away from the receiver

Plug this equipment into a different outlet so that equipment and receiver are on different branch circuits.

If necessary, the user should consult the dealer or an experienced radio/television technician for additional suggestions. The user may find the following booklet prepared by the Federal Communications Commission helpful:

"How to Identify and Resolve Radio-TV Interference Problems".

This booklet is available from the U.S. Government Printing Office, Washington, DC 20402, Stock No. 004-000-00345-4.

- As the laser beam used in this compact disc player is harmful to the eyes, do not attempt to disassemble the cabinet. Refer servicing to qualified personnel only.

FCC WARNING:

This equipment may generate or use radio frequency energy. Changes or modifications to this equipment may cause harmful interference unless the modifications are expressly approved in the instruction manual. The user could lose the authority to operate this equipment if an unauthorized change or modification is made.

NOTE:

This equipment has been tested and found to comply with the limits for a Class B digital device, pursuant to Part 15 of the FCC Rules. These limits are designed to provide reasonable protection against harmful interference in a residential installation. This equipment may cause harmful interference to radio communications, if it is not installed and used in accordance with the instructions. However, there is no guarantee that interference will not occur in a particular installation. If this equipment does cause harmful interference to radio or television reception, which can be determined by turning the equipment off and on, the user is encouraged to try to correct the interference by one or more of the following measures:

- Reorient or relocate the receiving antenna.
- Increase the separation between the equipment and receiver.
- Connect the equipment into an outlet on a circuit different from that to which the receiver is connected.
- Consult the dealer or an experienced radio/TV technician for help.

SAFETY PRECAUTIONS

▲ WARNING

Observe the following instructions to prevent fires and personal injury.

- Make sure that metal objects, particularly needles or coins do not get into the unit to prevent short-circuiting and fires.
- If smoke comes out of the unit or a strange smell is present, disconnect the unit immediately and consult your KENWOOD dealer. Continued use under these circumstances could cause a fire, as well as damage the unit permanently.

▲ CAUTION

Heed the following instructions to keep the unit in proper working order.

- Do not open enclosures, such as the front panel, top or bottom covers.
- Do not place the unit, where it will be exposed to direct sunlight or near heating devices.
- Do not expose the unit to water.
- Do not place the unit in areas of excessive dust, high humidity or on unstable surfaces.

NOTE

- If you have difficulty in installing the set in your car, please contact your KENWOOD dealer.
- If you should visit your KENWOOD dealer for servicing, please bring the this unit and the Control unit together.
- As the laser beam used in this compact disc player is harmful to the eyes, do not attempt to disassemble the cabinet. Refer servicing to qualified personnel only.

Cleaning

1. Turn the power off, before cleaning the unit.
2. Wipe the front panel and other exterior surfaces of the unit with a soft dry cloth or a soft cloth lightly moistened with a neutral detergent.

▲ CAUTION

- Do not use abrasive pads, thinner or benzene (or other volatile solvents) to clean the unit as this may remove indicator characters.



BEFORE USE



Note on Operation

- This CD player is designed to be controlled by the Control unit connected to it. The operations and display are performed on the Control unit, so please refer to the Instruction manual of the Control unit for these matters.

About Condensation

- When a disc or disc magazine is brought from a low-humidity place to a car where there is high humidity due to rain, etc. water vapor may condense on the disc. Or, when the main unit of the changer is installed under the dashboard, condensation may occur on the surface of the optical lens immediately after turning on the heater. If the CD player is operated in this condition, the laser pickup may not correctly read out the signal, or dropouts may occur occasionally. Thus, correct operation may not be obtained. In such cases, dehumidify the disc, or remove the disc magazine from the changer and leave it for about one hour, at which time correct operation will resume.
If the CD player does not operate correctly after a long time interval, consult your dealer or nearest KENWOOD Service Station.

About Temperature

- When a car is left in direct sunlight with the windows closed, the inside of the car will be greatly humidified, especially on the top of the dashboard. When the temperature exceeds 60°C, the built-in protection circuit may be activated, to prevent the optical system from being damaged, and thus the CD player will not function. In this case, re-install the main unit of the CD changer in a place which is less subject to humidity.

Handling of compact disc

- Stains, dust or scratches on the disc or warping of the disc will cause malfunction such as skipping. Handle the disc in the following manner so that you may enjoy the beautiful sound of the CD Player for a long time.

< Handling the disc >

Hold the disc without touching the music storage area (glistening rainbow colors). Do not apply a paper tape to the label on the disc nor to the music storing area.

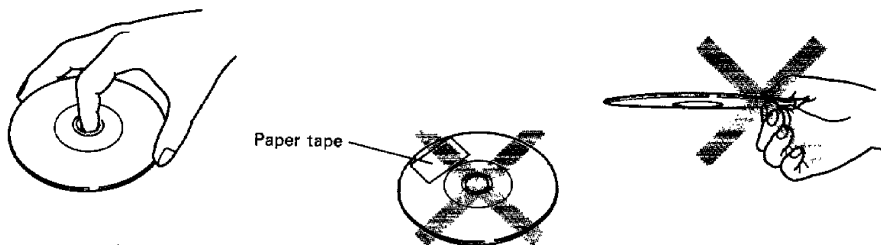

< Storage of compact disc >

- Do not put the disc where it is exposed to direct sunlight, heat or humidity.
- Especially in summer, never leave the disc exposed to direct sunlight or placed on the seat or dashboard with the windows closed because the temperature will rise considerably and the disc will warp.
- When the player is not in use for an extended period of time, remove the disc magazine from the changer, and store it in a place which is not subject to high temperature or high humidity.
Be sure to store the discs in their cases or in the magazine. Do not leave them outside of the case or magazine, or piled up, or leaning on a slant. This may cause scratches, dirt or warping.

< Cleaning of compact disc >

If there are fingerprints or stains on the disc, remove them by lightly wiping it with soft cotton cloth from the center toward the outside edge. Never use thinner or benzene. Also, avoid using conventional record cleaner.

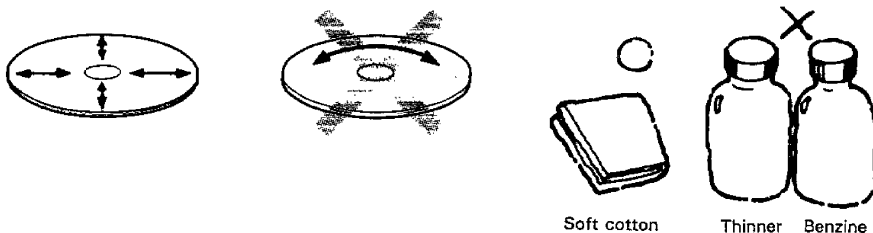

TABLE OF CONTENTS



■ OPERATION.....	7
■ LOADING COMPACT DISCS	8
■ ACCESSORIES	10
■ SCREW ADJUSTMENT FOR INSTALLATION ORIENTATION	11
■ INSTALLATION (Mounting diagram 1)	12
(Mounting diagram 2)	14
(Mounting diagram 3)	16
■ CONNECTIONS	17
■ TROUBLE SHOOTING GUIDE	18
■ SPECIFICATIONS	20

■ Operation of the Main Unit

Use of this unit requires connection to a control unit. Since all operations are carried out on the control unit side, be sure to carefully read the instruction manual supplied with the control unit.

■ Disc Magazine Memory Function

When using the control unit with the built-in memory play function, memory play data for up to six disc magazines can be memorized in the player. Simply insert a loaded disc magazine into the player and set the desired memory play settings. The player automatically checks and memorizes the magazine ID when the magazine is inserted. After that, whenever that magazine is inserted and the normal memory play operation is carried out, the player recalls the preset memory play settings for that magazine and plays the discs accordingly.

NOTE

- The "ID" of each disc magazine is the disc in the magazine's No. 1 slot. Therefore, if the No. 1 disc is replaced with a different disc, the player will identify the magazine as a different magazine, making it is necessary to carry out the memory play setting procedure again.
- If the magazine does not contain a disc in the No. 1 slot, the player identify that this type of magazines is the same.
- When the seventh different disc magazine is inserted, the player automatically erases the memory contents for the disc magazine which has not been inserted for the longest period of time (even if the memory play setting procedure is not carried out).
- If memory play settings are not made for a magazine, memory play operation will not be carried out for that magazine.



LOADING COMPACT DISCS

11111111

1

Labeled surface

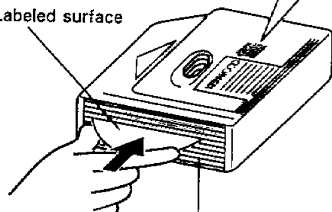

10 discs, one in each slot

- Discs are numbered in sequence (1, 2, 3...) from the bottom slot up. Insert discs into the magazine with their labeled sides facing up.

To remove



- To remove a disc from the magazine, press on the rear of the magazine so that it slides out the front. Do not use too much force or the disc may fly out the front of the magazine.

▲ CAUTION

8 cm (3 in) CDs cannot be used in this unit. If an 8 cm (3 in) CD adapter is used, the disc will not eject.

2

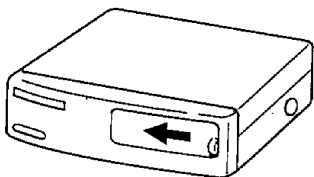

- Open the door of the unit.

3

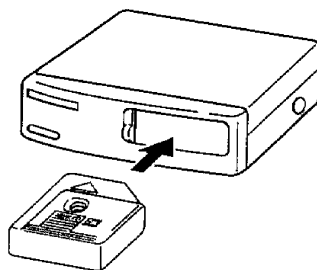

- Insert the disc magazine into the unit.

NOTE

Insert the disc magazine till it clicks.

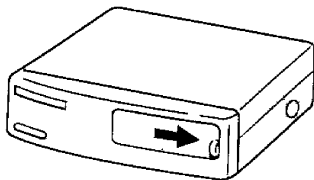
4

- Dust entering the unit will make the laser pickup dirty and adversely affect performance. Always be sure to keep the door closed.

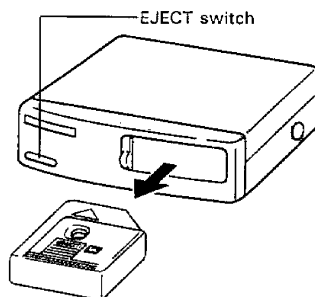
5

- To remove the disc magazine, open the door and then press the EJECT switch.

NOTE

The magazine will not eject if the door is not completely open.

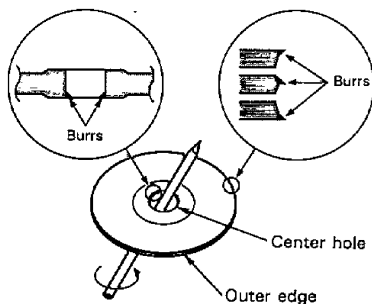





▲ CAUTION**<When using a new disc>**

- Before using a new disc, be sure to check for burrs around the edges of the disc's center hole and outer circumference (see diagram at left). If burrs are present, use a ballpoint pen or similar instrument to remove them. If a disc is used with burrs still attached, the disc may not fit properly in the player or disc magazine, or the sound may tend to skip during playback.

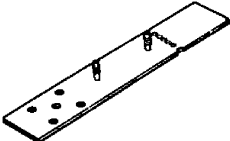
<Disc accessories>

- There are several types of disc accessories (stabilizers, protective seals, etc.) on the market designed for various purposes such as sound quality improvement and disc protection. Use of such disc accessories will change the thickness or outer dimensions of the disc with the result that the disc will not conform to standard specifications. Discs with this type of accessory attached may cause the disc changer to malfunction and should therefore not be used with this unit.

ACCESSORIES

No.	Part name	External view	Number of units
①	Bracket		2
②	Plate		2
③	Tapping screw ($\phi 5 \times 20$)		4
④	Washer assembly screw (M5 \times 12)		4
⑤	Nut (M5)		4
⑥	Sub-bracket		2
⑦	Changer extension cord (5 m)		1
⑧	Tape		2

⚠ CAUTION

- When installing this unit, be sure to use the screws supplied with the unit. Using screws which are longer than the supplied screws will damage the unit's internal components.

SCREW ADJUSTMENT FOR INSTALLATION ORIENTATION

- Be sure to turn the screw on the bottom of the unit according to the changer's installation orientation (horizontal or vertical). (The spring is set for horizontal installation when the unit is shipped from the factory.)

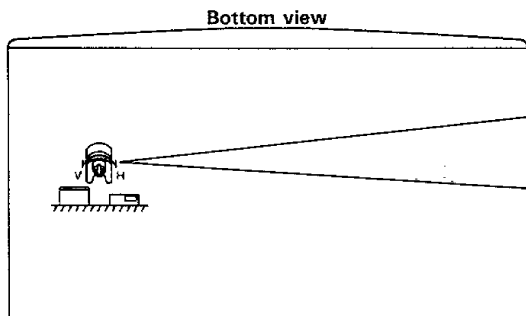

CAUTION

- The screw will not turn any further once it locks.
- If the screw is turned with the magazine inserted, the unit may be damaged. Be sure to eject the magazine before turning the screw.
- Turn the screw while pushing the screwdriver lightly.



- **Vertical installation**
(Turn the screw 180° to the left.)

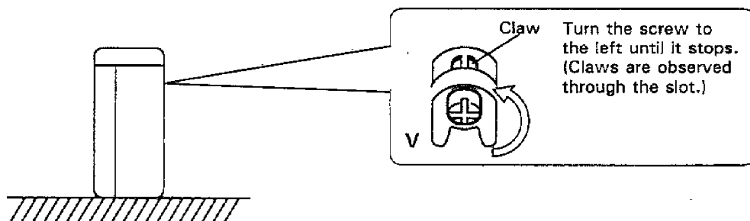

- **Horizontal installation**
(When switching from a vertical to horizontal installation, turn the screw 180° to the right.)

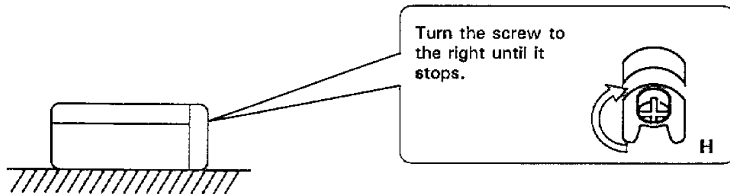

INSTALLATION

Mounting Diagram 1

Horizontal installation

- 1** Paste tape ⑧ on plate ②. Attach the bracket ① to the main unit and temporarily attach the plate ② to the bracket. (Do the same for the left side also.)

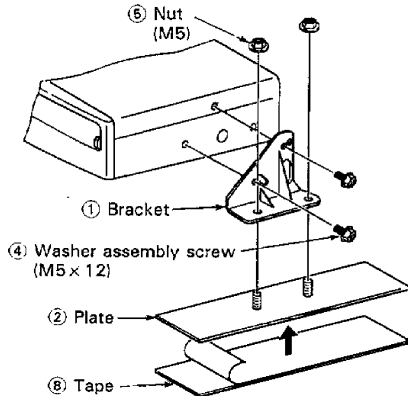

- 2** Pull up the carpet, peel off the protective paper of tape ⑧ to expose the adhesive on the bottom of the plates ② and place the unit in the desired installation position so that the plates adhere to the surface.

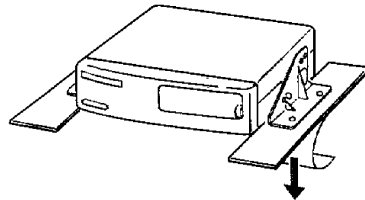

NOTE

Wipe stains as oil on the installation surface. And make sure the surface is flat.

- 3** Cut the carpet at the points where the plate ② bolts protrude.

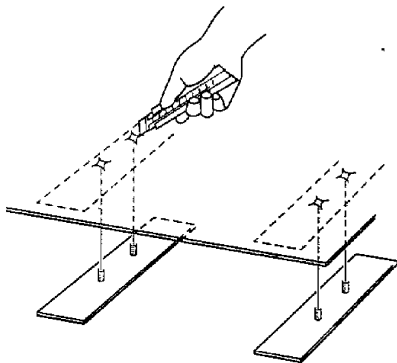

- 4** With the carpet in place, use the 4 nuts (M5) ⑤ to secure the changer in the installation position.

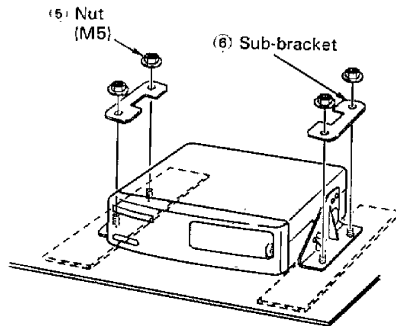

- Installation method 1 is a simple installation method. If the sound skips when CDs are played, reinstall the unit using installation method 2 (see the next page.)

Vertical installation

- 1** Paste tape ⑧ on plate ②. Turn the screw on the bottom of the unit (see P. 11). Attach the bracket ① to the main unit and temporarily attach the plate ② to the bracket. (Do the same for the left side also.)

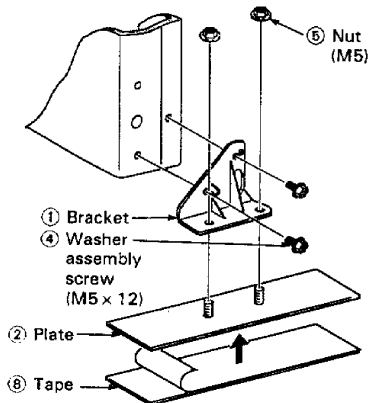

- 2** Pull up the carpet, peel off the protective paper to expose the adhesive on the bottom of the plates ② and place the unit in the desired installation position so that the plates adhere to the surface.

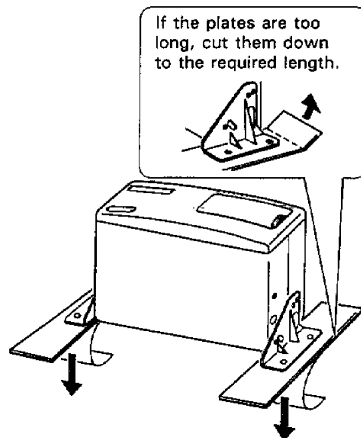

- 3** Cut the carpet at the points where the plate ② bolts protrude.

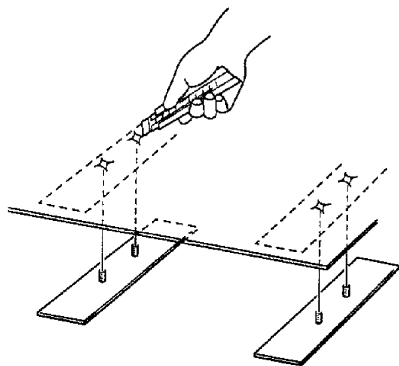

- 4** With the carpet in place, use the 4 nuts (M5) ⑤ to secure the changer in the installation position.

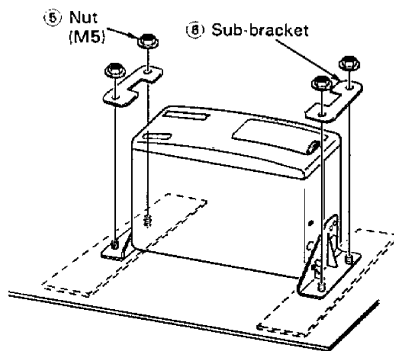

INSTALLATION

Mounting Diagram 2

Horizontal installation

1 Attach the brackets ① to the main unit.

Attach the brackets with the screws inserted in the blackened holes. (Do the same for the left side also.)

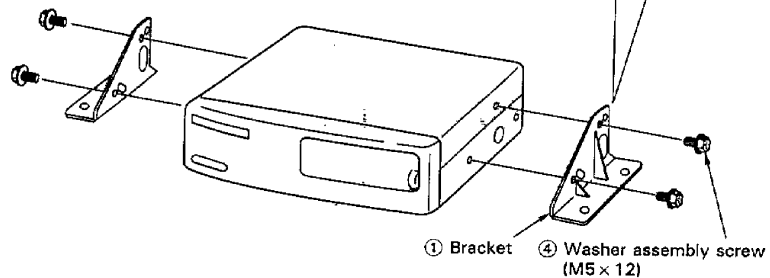

2 Drill holes approximately 4 mm in diameter in the installation surface, align the bracket ① holes with the drilled holes and secure the unit in position.

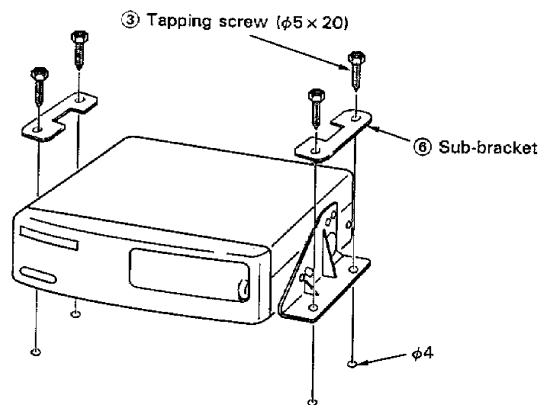

Vertical installation

- 1** Turn the screw on the bottom of the unit (see P. 11). Attach the brackets ① to the main unit.

Attach the brackets with the screws inserted in the blackened holes. (Do the same for the left side also.)

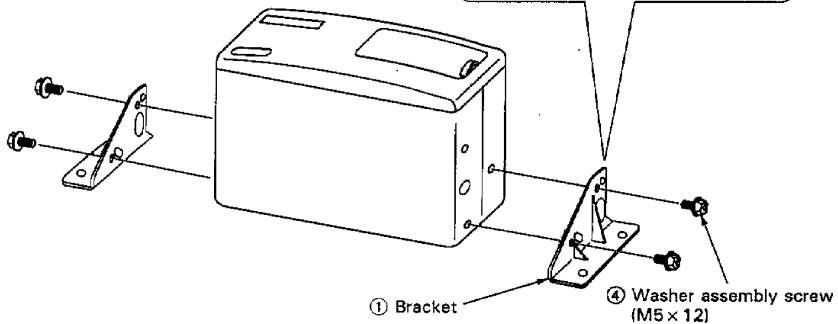

- 2** Drill holes approximately 4 mm in diameter in the installation surface, align the bracket ① holes with the drilled holes and secure the unit in position.

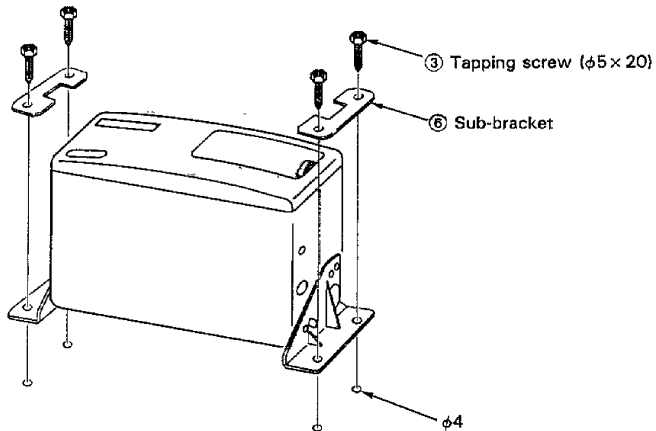

▲ CAUTION

When making the hole, make sure not to damage the fuel tank, brake tube, wiring harnesses, etc. on the other side.

INSTALLATION

Mounting diagram 3 (In case of hanging in the trunk)

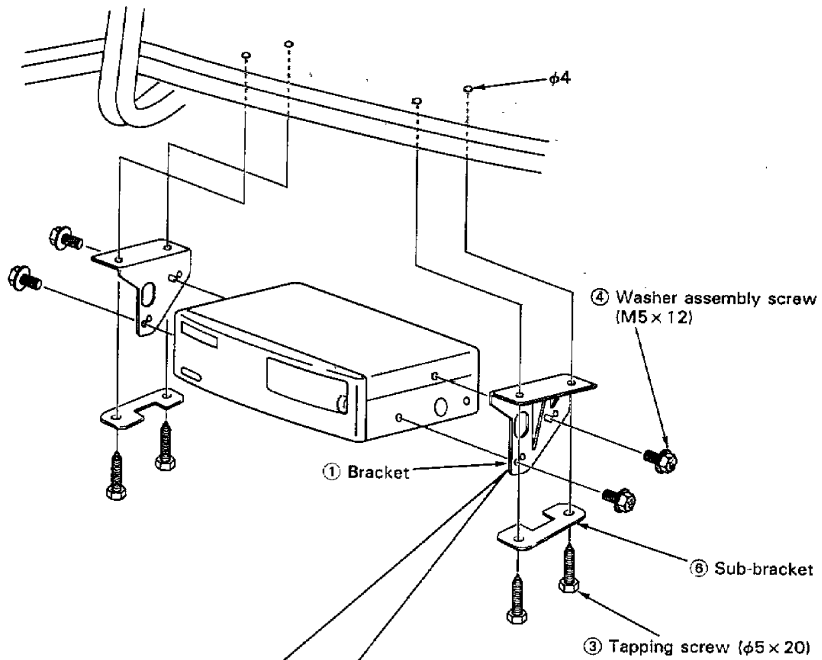

Attach the brackets with the screws inserted in the blackened holes. (Do the same for the left side also.)

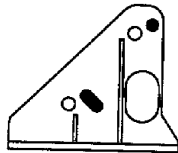

NOTE

- If the unit is installed near speakers, the speakers vibration causes a sound skip. Be sure not to do that.

CONNECTIONS

- For more detailed connection method, please refer to the Instruction Manual supplied with the Compact disc auto changer control unit.

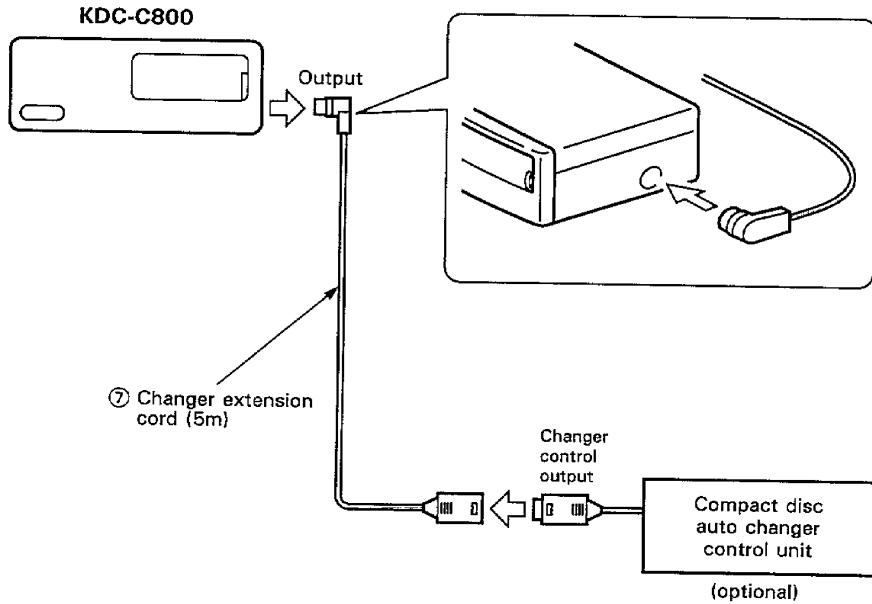

▲ CAUTION

- Do not install an antenna of radio equipment or distribute the antenna cable near the changer output cable, for this could cause malfunction with this unit.

TROUBLESHOOTING GUIDE

What often appears to be a malfunction is often due to user error in operation or connection. When trouble occurs with your unit, please check the following before calling for service.

Symptom	Cause	Remedy
Power is not turned ON.	<ol style="list-style-type: none"> 1. Output cable from the control unit is not connected. 2. The engine key switch of the car is not set to ON. 3. The incorporated microcomputer is not operating correctly due to some effect. 	<ol style="list-style-type: none"> 1. Connect the control unit cable correctly. 2. Set the engine key switch to ON. 3. Press the Reset button of the control unit.
Operation switches do not function.	Correct operation is not obtained due to a sudden change in the power voltage, etc.	Press the Reset button of the control unit.
CD play does not start.	<ol style="list-style-type: none"> 1. Player is set to the play-pause mode. 2. Power switch is not turned ON. 	<ol style="list-style-type: none"> 1. Press the CD (▷ □) switch. 2. Turn the power switch ON, then press the CD (▷ □) switch.
The specified disc is not played and the next disc is played.	<ol style="list-style-type: none"> 1. The specified disc is too dirty. 2. The disc is placed upside down. 3. Two discs are set in the same position. 4. The specified disc is placed in a position with a different number. 	<ol style="list-style-type: none"> 1. Clean the disc. (Refer to page 5.) 2. Eject the magazine and re-insert the disc correctly. 3. Eject the magazine and set each disc correctly. 4. Eject the magazine to check the disc number and the position number, then specify again.
Sound skips due to vibration.	<ol style="list-style-type: none"> 1. The unit is mounted at a slant. 2. Changer unit is mounted in an unstable place. 3. Luggage is in contact with the changer unit. 4. The installation screws are not installed correctly. 5. Changer unit is installed incorrectly. 6. Heavy scratches, dirt, or water drops are on the surface of the compact disc. 	<ol style="list-style-type: none"> 1. Mount the unit so that it is level. 2. Mount the unit in a stable place. 3. Set the luggage apart from the changer unit. 4. Install the screws correctly. (⇨ P. 11) 5. Install the unit correctly and firmly. 6. If the same section skips when the car is stopped, clean the disc referring to page 5.

Symptom	Cause	Remedy
Sound quality is bad, or noise is heard during play.	<ol style="list-style-type: none"> 1. Heavy scratches, dirt, or water drops are on the surface of the compact disc. 2. Original recording is old, or the quality of the compact disc is not very good. 	<ol style="list-style-type: none"> 1. Clean the disc referring to page 5. 2. If there is not problem with other discs, the sound quality depends on the disc itself.
No sound is output with the CD play (>) indication.	<ol style="list-style-type: none"> 1. Volume is set to the minimum level of the control unit. 2. The incorporated microcomputer is not operating correctly. 3. System connections are made imperfectly (power cord, connection of pre-out jacks, or speaker connections, etc.). 4. Fader is set all the way to the front or rear of the control unit. 	<ol style="list-style-type: none"> 1. Increase the volume level of the control unit. 2. Press the Reset button of the controller unit. 3. Check the connections according to the instruction manual. If anything is wrong, reconnect it correctly. 4. Set the fader to the center position between the front and rear channels of the control unit.
During program play, a track or disc which has been programmed is not played.	The disc is not set in the place corresponding to the stored program.	Perform programming again correctly.
Even when the required track is specified, the specified track is not played or the player does not function.	The control unit is set to random play or program play.	Release random play or program play.

SPECIFICATIONS

Specifications subject to change without notice.

Disc Section

Laser Diode	GaAlAs ($\lambda = 780 \text{ nm}$)
Digital Filter	8 Times Over Sampling
D/A Converter	1 bit
Sampling Frequency	44.1 kHz
Conversion Rate	176.4 kHz
Spindle Speed	500 ~ 200 rpm (CLV)
Wow & Flutter	Below Measurable Limit
Frequency Response ($\pm 1 \text{ dB}$)	5 Hz ~ 20 kHz
Total Harmonic Distortion (1 kHz)	0.005%
Signal to Noise Ratio	94 dB
Dynamic Range	94 dB
Channel Separation	85 dB

Laser Diode Properties

Material	GaAlAs
Wavelength	780 nm
Emission Duration	Continuous
Laser Output Power	Less than 44.6 μW

* This output is the value measured at a distance of 200 mm from the objective lens surface on the Optical Pick-up Block.

General

Operating Voltage	14.4 V (11 ~ 16 V)
Current Consumption	0.8 A
Operating Temperature	-10 ~ 50 °C
Installation Size (W x H x D)	281 x 76 x 171 mm (11-1/16 x 3 x 6-3/4 in.)
Weight	3.3 kg (6.8 lb)

KENWOOD